MACK DEFENSE

TRIBAL EDITION



Goshute Reservation - Granite Dump



Granite, the tried-and-true platform

Constructed with purpose. Prepared for anything. Mack Defense trucks are designed to match the demands of your most severe sites. Because we didn't just build America, we built a reputation as the leaders in construction.

LEGENDARY POWERTRAINS

Mack® powertrains are the standard for performance and reliability across a wide range of applications.

BEST-IN-CLASS CHASSIS

The Mack Cornerstone™ chassis is designed and engineered for the rigors of vocational work and the job at hand—your job.

PURPOSE-BUILT CABS

Tough meets comfortable in Granite's cab. From mirrors to switches to seats, Granite is designed to keep drivers comfortable and get work done.

BY YOUR SIDE 24/7

Mack Connect, our uptime and productivity solution, brings technology and service professionals together for round-the-clock support.

EASY APPLICATION CONFIGURATION

Industry-leading body builder support and BodyLink™ III wire harness connectors make body hookup easy and reliable.

LEGENDARY MP® ENGINES

Power is tuned for consistent speed and torque across the wide operating range required for hauling heavy construction loads in any condition.

MP®7

The updated 11-liter MP®7 engine drops 51 lbs. and gains up to 2.1% in fuel economy while offering up to 425 HP and 1,560 lb.-ft. of torque.

MP®8

Saving up to 2.5% in fuel and shedding 88 lbs. in weight, Mack's workhorse MP®8 engine offers up to 505 HP and 1,860 lb.-ft. of torque.

mDRIVE™ HD AUTOMATED MANUAL TRANSMISSION

Mack's mDRIVE HD automatically selects the best gear for the job—including 13- and 14-speed creeper gears and multi-speed reverse gears—to maximize fuel economy and reduce driver fatigue, all while weighing approximately 150 lbs. less than an automatic transmission.

32:1 Gear Ratio

The 14-speed has an extra-deep 32:1 gear ratio that allows for the low-speed creeping needed for controlled dumping.



mDRIVE HD Control Panel

ALL-NEW INTERIORS



CONTROL AT YOUR FINGERTIPS

New controls, steering wheel and instrument panel give drivers total confidence and control in the cockpit. An industry-first flat-bottom steering wheel allows more belly room and clearance for entry or exit. Automotive-inspired controls provide a familiar feel while the 5" digital display constantly monitors truck health and performance.



UNMATCHED COMFORT

A spacious cab and premium materials create an interior that's as comfortable as it is functional. Designed in partnership with Sears Seating, new, Mack-exclusive seats feature air suspension, an optional swivel base and more than 30 feature and fabric combinations.

"Here at Mack Defense, we have a hands on approach with our customers. Each truck is highly customizable to your specific needs and application. Your dedicated Sales Manager is there every step of the way ensuring a smooth process from initial spec through delivery."

Feature	Mack	Others
Galvanized steel cab for superior safety and durability.	✓	✗
Mack axles with unique top-mounted carrier for less driveline friction, maximum durability and superior ground clearance.	✓	✗
Automatic power divider that diverts up to 75% of available power to the wheels with traction, with no driver action required.	✓	✗
Unimax® axles that are maintenance-free while giving drivers exceptional front wheel cuts, clearance and turning radius. 20k and 23k lbs. rating include 5.3" center thickness for high gross weights.	✓	✗



Nunakauyak Traditional Council - 2020 - 4,000 gal Granite Water Tanker

GRANITE



White Mountain Apache Tribe - Granite Dump

Raising the bar for snow plow performance.

MORE GROUND CLEARANCE

6" increase in chassis ride height - Up to 21" of ground clearance for installation without relocating chassis components such as EATS, fuel tanks, battery boxes and air tanks

Allows underbody scraper to articulate a full 45° to either side; Modified steps maintain 24" of first step height

Mack axles have top-mounted carriers offering higher driveline clearance and making wing plow installation easier

SHORTENED WHEELBASE

A shorter wheelbase makes it easier to get in and out of tight spots. Mack's underbody scraper option, combined with the ground clearance of Granite axle-forward models, opens new possibilities to shorten your wheelbase and extend your maneuverability.

Medium Duty, built for growth.

Dependability, durability and steadfast support—everything you’ve come to expect from Mack Defense is now available in a medium-duty truck. We’re proud to introduce the MD Series. These trucks are packed from the exterior to the driver environment with features that ensure a smooth, stress-free ride—backed by our unmatched local dealer support when you need it. We’ve taken care of the details so you can focus on growing your business.



KEY FEATURES

Cab air suspension (standard)

Full-width aluminum grated steps for easy entry and egress, horizontally offset for visibility (standard)

50-gallon fuel tank (standard), 90-gallon (optional)

Frame rails rated at 120,000 psi yield strength (standard)

34-inch assembled frame width

Rear leaf spring suspension (standard), Mack AirRide (optional)*

*Mack Maxlite air ride available on select wheelbases only.

Tires 11R22.5 All Season (standard), Rear Traction tires (optional)

Steel powder coat disc wheels (standard), aluminum wheels (optional)

Passenger door lower peep window (standard)

Flat back-of-cab and clear frame platform for easy body installation

Clear areas on driver and passenger side frame rails

FIND THE RIGHT FIT

Choose from a range of eight different wheelbase sizes – from 10 to 26 ft. – to get the perfect size for your applications needs.

VERSATILITY

Each of our MD Series trucks come with a wide selection of upgrade options—for size, traction and power that feel custom made.

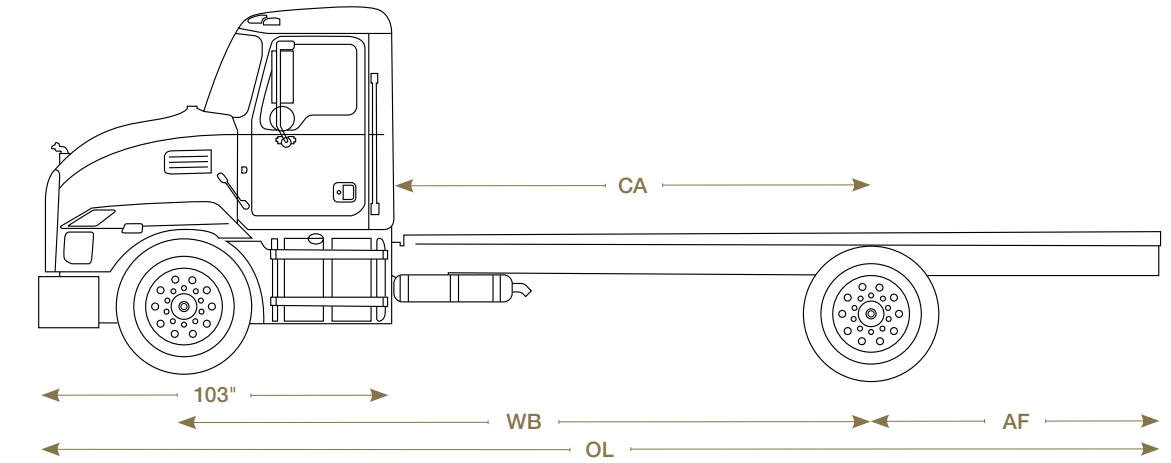

MD6 SPECIFICATIONS

Typical Dry Van Body Length (ft.)		10	12/14	16	18	20	22	24	26
Wheelbase*	WB (in.)	150	166	186	206	221	236	251	270
Cab to Rear Axle	CA (in.)	87	103	123	143	158	173	188	207
After Frame	AF (in.)	50	55	60	65	70	80	90	100
Overall Length Chassis	OL (in.)	240	261	286	311	341	356	381	410
GVWR	(lb.)	25,995	25,995	25,995	25,995	25,995	25,995	25,995	25,995
Front Axle Capacity	(lb.)	10,000	10,000	10,000	10,000	10,000	10,000	10,000	10,000
Rear Axle Capacity	(lb.)	17,000	17,000	17,000	17,000	17,000	17,000	17,000	17,000
Front Axle Weight	(lb.)	6,080	6,210	6,250	6,315	6,345	6,395	6,440	6,470
Rear Axle Weight	(lb.)	3,490	3,425	3,450	3,470	3,515	3,550	3,590	3,640
Total Chassis Weight**	(lb.)	9,570	9,635	9,700	9,785	9,860	9,945	10,030	10,110

MD7 SPECIFICATIONS

Typical Dry Van Body Length (ft.)		10	12/14	16	18	20	22	24	26
Wheelbase*	WB (in.)	150	166	186	206	221	236	251	270
Cab to Rear Axle	CA (in.)	87	103	123	143	158	173	188	207
After Frame	AF (in.)	50	55	60	65	70	80	90	100
Overall Length Chassis	OL (in.)	240	261	286	311	341	356	381	410
GVWR	(lb.)	33,000	33,000	33,000	33,000	33,000	33,000	33,000	33,000
Front Axle Capacity	(lb.)	12,000	12,000	12,000	12,000	12,000	12,000	12,000	12,000
Rear Axle Capacity	(lb.)	21,000	21,000	21,000	21,000	21,000	21,000	21,000	21,000
Front Axle Weight	(lb.)	6,180	6,235	6,275	6,340	6,375	6,400	6,450	6,500
Rear Axle Weight	(lb.)	3,450	3,465	3,495	3,525	3,575	3,620	3,665	3,715
Total Chassis Weight**	(lb.)	9,630	9,700	9,770	9,865	9,650	10,020	10,115	10,215

*Wheelbase selection should be based on specific weight distribution. **Total Chassis Weight is for standard specifications EXCLUDING driver and fuel.



MD 6 does not require a non CDL. Options include dump body, water tanker, dry van body, cargo bed, fuel/lube, and service.

TerraPro, built to withstand the full abuse of refuse.

Built to perform the toughest jobs in the tightest spaces, TerraPro is the refuse industry's best-selling cabover. Ideal for industrial and commercial applications, this truck improves productivity and reduces downtime while providing all-out cabin comfort.

Exceptional visibility

TerraPro's large mirrors combined with the most forward window glass in the industry create superior visibility so you can keep pedestrians, other vehicles and side-loading jobs safely in view.

Alternative fuels

TerraPro natural gas models use LNG or CNG for lower overall lifecycle and fuel costs, as well as lower greenhouse gas (CO₂) emissions and reduced carbon footprint.

Body-ready electrical system

Cabovers come equipped with body-ready electrical systems so installation time is reduced. These systems ensure quality and prevent future reliability issues.

Axle configurations

Available in single and tandem configurations, TerraPro can be customized with multiple drive and auxiliary axle combinations.

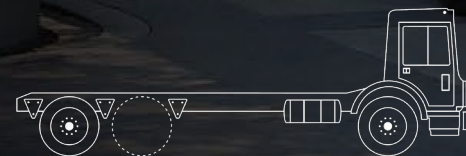

Improved productivity

Mack's long experience with all aspects of the refuse industry means we know how to boost your productivity. The fuel-efficient yet high-torque Mack® MP[®]7 engine delivers faster route times and less downtime. And Mack's chassis engineering packs the maximum allowable payload into a compact overall dimension.

Capture comfort

Mack's contemporary cab provides ergonomic seats and controls to create an optimal driving experience.

Superior maneuverability

With a short wheelbase, slimmer width and more compact design from bumper to back of cab, TerraPro's cabover design makes navigating even the most congested neighborhoods safer and more efficient.



GuardDog® Connect

Whenever your truck is operating, GuardDog Connect is monitoring your performance to identify issues, schedule repairs and order parts—all while you're still on the road. And with a 24/7 network of support staff connecting you to nearby repair centers, you'll get back on the road quickly, so you can stay on schedule.



Mack ASIST

Our web-based system assembles consistent, complete and professional estimates of service recommendations, regardless of which dealer in the Mack network performs the service. Mack ASIST gives driver, dealer and Uptime Center staff access to all of the information needed to get you back on the job.



OneCall®

OneCall provides 24/7 roadside assistance support for your truck. It connects drivers to our unparalleled network of experienced technicians via our state-of-the-art Uptime Center to get you back on the road quicker than ever before.



Over The Air (OTA) Software Updates

Software updates and parameter changes will no longer disrupt your schedule. This industry-leading uptime solution works with Mack® GuardDog® Connect to let you wirelessly update engine, transmission and after treatment system software at your convenience.

info@mackdefense.com

mackdefense.com

facebook.com/MackDefense

twitter.com/MackDefense

instagram.com/mackdefense

youtube.com/c/MackDefenseLLC

linkedin.com/company/mack-defense-llc

Weights, dimensions and features are given for reference and may be modified according to the choice of certain options. Mack Defense, LLC, reserves the right to modify the above specifications without prior notification.

©2023 Mack Trucks, Inc. All rights reserved. Mack, and the Bulldog design, Bulldog and all other marks contained herein are registered trademarks of Mack Trucks, Inc. and/or Mack Trucks, Inc. Affiliated companies. All other marks contained herein are the property of their respective owners.

